

**VARIABLE SWIRL DIFFUSER
WR300**

Installation dimensions

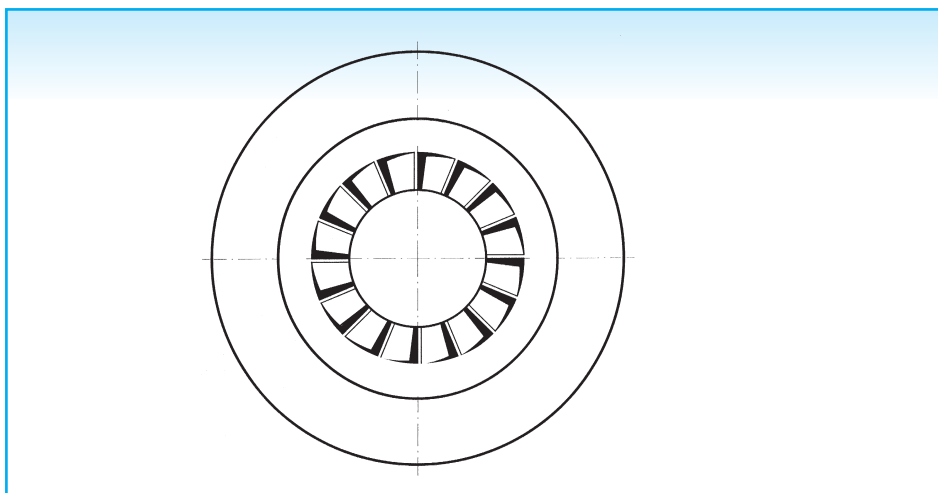
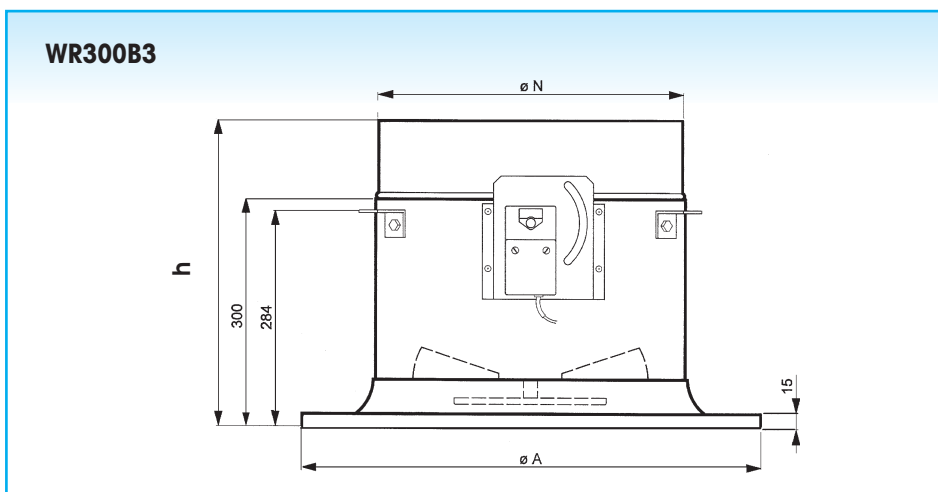
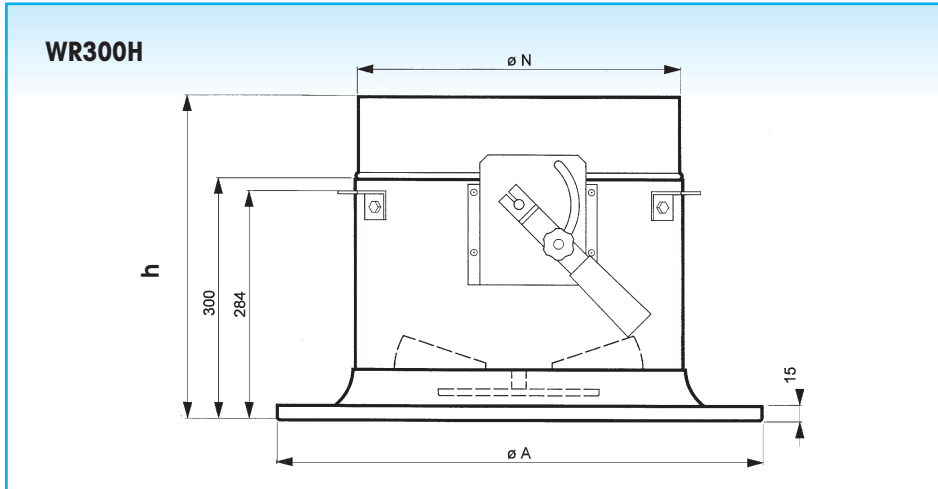

Size	Ø N	Ø A	h
250	247	363	355
315	312	448	365
400	397	600	400

All dimensions in mm.

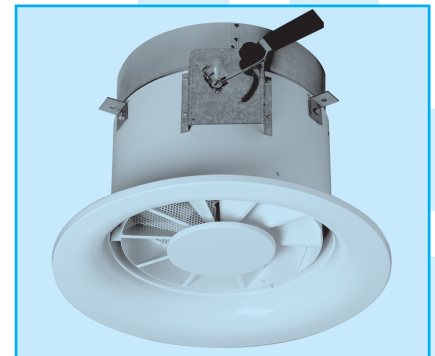

Application

- Swirl diffuser for ceiling or exposed duct mounting. Specially designed for spaces where considerable temperature changes take place and with ceiling heights of more than 4m, where high comfort standards are required. It can be used for commercial (conference rooms, ...) or industrial installations (industrial halls, airports, theatres, bank buildings, ...).
- Heated, cooled or isothermal air can be supplied by an adapted air pattern. Cold air has a tendency to 'drop', making it advisable to spread that air horizontally. Warm air however, can remain too close to the ceiling, not reaching the occupied zone. The variable swirl diffuser WR300, which can handle supply temperature differences of -10K up to +15K, can solve those problems.
- Changing the vertical air pattern into a horizontal one always guarantees the desired air distribution for cooling as well as heating. Because of this, a diffuse movement of the air is created in the occupied zone, with low air velocity and a draught-free ventilation.
- In the heating mode warm air is passed through the slots in the outer ring of the swirl diffuser projecting the air down into the space. The centre swirl section of the diffuser is not active. When in the cooling mode the outerring is closed and air passes through the swirl vanes resulting in a horizontal air distribution pattern. The outer ring is not active. A constant pressure loss is always guaranteed, in the highest positions as well as in all the variable intermediate positions.

3

Technical information

Characteristics:

- 2 way air pattern adjustment:
 - manually
 - motorised (power supply 24 AC/DC operating signal 0-10V DC)
- By positioning the mechanism outside the diffuser, manual and motorised control are entirely interchangeable without having to remove the swirl diffuser.
- Circular entry
- 4m < mounting height < 12m

Construction:

- Swirl sheet (galvanised steel sheet) and external diffuser collar (steel sheet) painted RAL 9010
- Inlet collar in galvanised steel sheet

Specifications description

Example:

Motorised variable swirl diffuser with fixed swirl vanes. External diffuser collar and swirl sheet in steel sheet. Adjustable core, resulting in either a horizontal or vertical air pattern, in accordance with the internal thermal pressure. The diffuser is painted white (RAL 9010).

Type: **WR300B3**
size ... mm

Fixing

With mounting straps attached to the external diffuser collar (3 mounting straps at 120°)

Delivery possibilities

- **WR300:** without control (mounting sheet is present)
- **WR300H:** manual control by handle
- **WR300B3:** motorised control Belimo LM24A-SR

How to order

WR300, size 400 mm, with motorised control Belimo LM24A-SR

W	R	3	0	0	B	3	0	4	0	0	0	0	0	0
---	---	---	---	---	---	---	---	---	---	---	---	---	---	---

Size

-- : without control
H- : manual control
B3: motorised control Belimo LM24A-SR