

Fig. 1

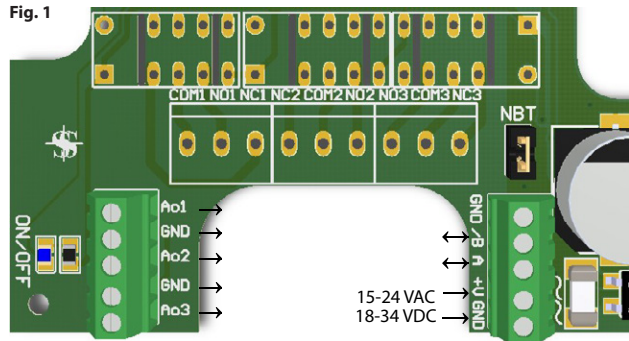
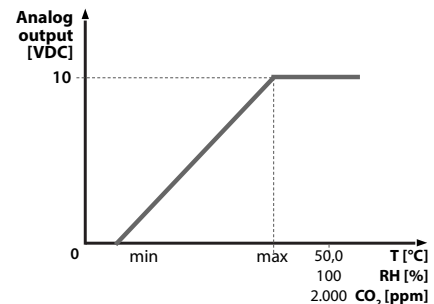

Fig. 2



The output voltage starts to rise from 0 VDC at minimum sensor range and reaches 10 VDC at maximum sensor range.

Fig. 3

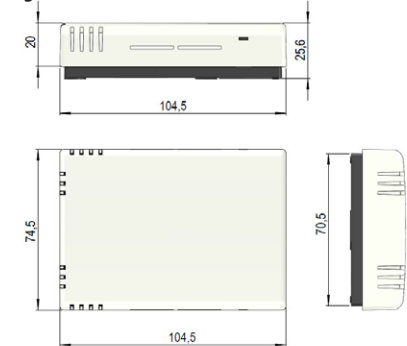

Fig. 4

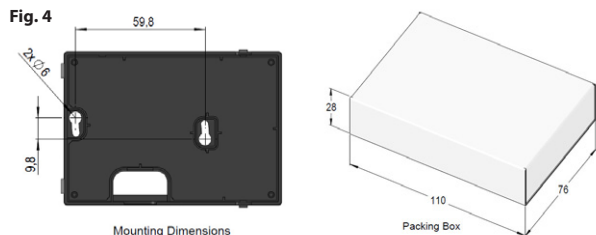
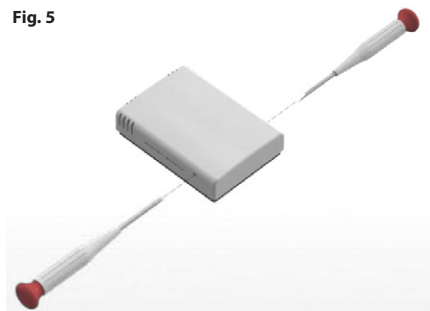

Fig. 5



Weight
120 g

EN MOUNTING INSTRUCTIONS

RSMF | multifunctional room transmitter

The RSMF multifunctional room transmitter measures temperature, relative humidity and CO₂ with four predefined ranges and one user-definable range, using self-calibrating and maintenance-free sensors. The sensor contains three analog outputs (0-10 VDC/0-20 mA) and also Modbus RTU communication for easy network access.

Article code

RSMFG

Technical data

- Power supply: 24 VAC/VDC±10 %
- 3 analog outputs: 0-10 VDC/0-20 mA
load resistance in 0-10 VDC mode should be more than 500 Ω
load resistance in 0-20 mA mode should be less than 500 Ω
- Measuring range
temperature: 0-30 °C/10-40 °C/20-50 °C/0-50 °C
relative humidity: 2-90 %/0-60 %/0-80 %/0-100 %
CO₂: 450-1850 ppm/0-1000 ppm/0-1500 ppm/0-2000 ppm
user-definable ranges possible with Modbus RTU communication and 3SModbus
- Hysteresis fixed: 2 °C, 5 %, 100 ppm
- Modbus RTU (RS485)
- Blue LED operation indication
- Operating temperature: -10 to 50 °C

Power consumption

- No load: max. 80 mA
- Full load: max. 140 mA

Enclosure

- Front: ASA plastic, ivory RAL9010
- Back: ABS plastic, black RAL9004
- Protection: IP30

Standards

- CE conform
- EMC Directive 2004/108/EC: EN 61000-6-3:2007, EN 61000-6-2:2006 and EN 60730-1:2011
- Low Voltage Directive Directive 2006/95/EC

Intended area of use

- Maintaining temperature, relative humidity and CO₂ levels in buildings and private houses

Connections (see fig. 1)

AO	analog output 1 (0-10 VDC/0-20 mA)
GND	ground
AO2	analog output 2 (0-10 VDC/0-20 mA)
GND	ground
AO3	analog output 3 (0-10 VDC/0-20 mA)
GND	ground
/B	RS485 signal /B
A	RS485 signal A
+V	supply: 24 VAC/VDC±10 %
GND	ground

Settings

JUMPERS SENSOR RANGE

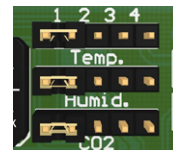

Position	Temperature	Jumper on pins
1	0-30 °C (default)	1 & 2
2	10-40 °C	2 & 3
3	20-50 °C	3 & 4
4	0-50 °C	4 & 5

Position	Humidity	Jumper on pins
1	20-90 % (default)	1 & 2
2	0-60 %	2 & 3
3	0-80 %	3 & 4
4	0-100 %	4 & 5

Position	CO ₂	Jumper on pins
1	450-1850 ppm (default)	1 & 2
2	0-1000 ppm	2 & 3
3	0-1500 ppm	3 & 4
4	0-2000 ppm	4 & 5

JUMPERS ANALOG OUTPUT

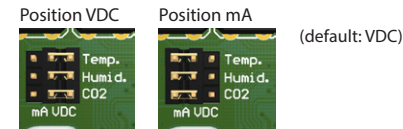

JUMPER RESET MODBUS SETTINGS

Put and hold jumper on position 1-2 for 20 sec.



JUMPER NETWORK BUS TERMINATION RESISTOR

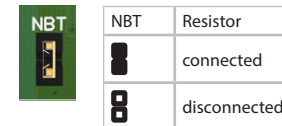

Note: putting a jumper on only one pin is the same as 'off', no connection is made.

Mounting (see fig. 4)

The device is to be mounted in a room on a smooth surface, preferably at a minimum height of 1,50 m above the floor.

- Open the cover by releasing the locking plates (see fig. 5) on both sides of the box and remove it.
- Perform wiring after switching off the power supply. Arrange appropriate cable lengths inside the standard cable joint boxes installed inside the wall.
- Attach the device to the cable joint box or wall using standard fastening materials via the mounting holes on the box according to the fixing dimensions.
- If all connections and settings are done, close the cover.

Transport and stock keeping

Avoid shocks and extreme conditions, stock in original packing.
Storage temperature: -40 to 50 °C.

Warranty

Two years from delivery date against defects in manufacturing. Any modifications or alterations to the product relieve the manufacturer of all responsibility.

Input registers (Read)

		Data type	Description	Data	Values
1	Temp. level	signed int.	Actual temperature level		500 = 50,0 °C
2	Rel. humidity level	unsigned int.	Actual relative humidity level		1000 = 100,0 %
3	Dewpoint	signed int.	Calculated dewpoint		200 = 20,0 °C
4	CO ₂ level	unsigned int.	Actual CO ₂ level		2000 = 2.000 ppm
5			Reserved, returns 0		
6			Reserved, returns 0		
7			Reserved, returns 0		
8			Reserved, returns 0		
9			Reserved, returns 0		
10			Reserved, returns 0		
11	Temperature output value	signed int.	Value of analog output for temperature Ao1	0 - 1.000	0 = 0 VDC 1000 = 10,00 VDC
12	Relative humidity output value	signed int.	Value of analog output for relative humidity Ao2	0 - 1.000	0 = 0 VDC 1000 = 10,00 VDC
13	CO ₂ output value	signed int.	Value of analog output for CO ₂ Ao3	0 - 1.000	0 = 0 VDC 000 = 10,00 VDC
17	Selected temperature range	signed int.	Temperature working range selected by jumper or holding register	1 2 3 4 5	1 = 0 - 30 °C 2 = 10 - 40 °C 3 = 20 - 50 °C 4 = 0 - 50 °C 5 = XX - XX °C
18	Selected relative humidity range	signed int.	Relative humidity working range selected by jumper or holding register	1 2 3 4 5	1 = 20 - 90 % 2 = 0 - 60 % 3 = 0 - 80 % 4 = 0 - 100 % 5 = XX-XX %
19	Selected CO ₂ range	signed int.	CO ₂ working range selected by jumper or holding register	1 2 3 4 5	1 = 450 - 1850 ppm 2 = 0 - 1000 ppm 3 = 0 - 1500 ppm 4 = 0 - 2000 ppm 5 = XXXX - XXXX ppm
29	Calibration timer	unsigned int.	Returns passed time in % for 10 min calibration procedure in progress, returns 0 when inactive	0 - 100	100 = 100 %
30			Reserved, returns 0		

Holding registers (Read/Write)

		Data type	Description	Data	Values
1	Device slave address	unsigned int.	Modbus device address	1 - 247 (default: 1)	
2	RS485 baud rate	unsigned int.	Modbus communication baud rate	1 = 9.600 2 = 19.200 (default) 3 = 38.400 4 = 57.600	
3	RS485 parity mode	unsigned int.	Parity check mode	0 = 8N1 1 = 8E1 (default) 2 = 8O1	
4	Device type	unsigned int.	Device type, read-only	1000 = RSMFG	

		Data type	Description	Data	Values
5	HW version	unsigned int.	Hardware version of the device, read-only	XXX	0x0120 = HW version 1.20
6	SW version	unsigned int.	Software version of the device, read-only	XXX	0x0120 = SW version 1.20
7	Operating mode	unsigned int .	Enables Modbus control and disables jumpers and trimmers	0 = standalone mode (default) 1 = Modbus mode	
8	Output override	unsigned int.	Enables direct control over the outputs, always settable, active only if holding register 7 is set to 1	0 = disabled (default) 1 = enabled	
9			Reserved, returns 0		
10			Reserved, returns 0		
11	Temperature range select	signed int.	Select temperature working range, always settable, active only if holding register 7 is set to 1	1 (default) 2 3 4 5	1 = 0 - 30 °C 2 = 10 - 40 °C 3 = 20 - 50 °C 4 = 0 - 50 °C 5 = custom
12	Relative humidity range select	signed int.	Select relative humidity working range, always settable, active only if holding register 7 is set to 1	1 (default) 2 3 4 5	1 = 20 - 90 % 2 = 0 - 60 % 3 = 0 - 80 % 4 = 0 - 100 % 5 = custom
13	CO ₂ range select	signed int.	Select CO ₂ working range, always settable, active only if holding register 7 is set to 1	1 (default) 2 3 4 5	1 = 450 - 1850 ppm 2 = 0 - 1000 ppm 3 = 0 - 1500 ppm 4 = 0 - 2000 ppm 5 = custom
14	Min. temperature custom range	signed int.	Minimum value of temperature custom range, always settable, active only if holding register 7 is set to 1 and register 11 is set to 5	0 - Max (default: 0)	100 = 10,0 °C
15	Max. temperature custom range	signed int.	Maximum value of temperature custom range, always settable, active only if holding register 7 is set to 1 and register 11 is set to 5	Min - 500 (default: 500)	500 = 50,0 °C
16	Min. relative humidity custom range	signed int.	Minimum value of relative humidity custom range, always settable, active only if holding register 7 is set to 1 and register 12 is set to 5	0 - Max (default: 0)	200 = 20,0 %
17	Max. relative humidity custom range	signed int.	Maximum value of relative humidity custom range, always settable, active only if holding register 7 is set to 1 and register 12 is set to 5	Min - 1.000 (default: 1.000)	1.000 = 100,0 %
18	Min. CO ₂ custom range	signed int.	Minimum value of CO ₂ custom range, always settable, active only if holding register 7 is set to 1 and register 13 is set to 5	0 - Max (default: 0)	1.000 = 1.000 ppm
19	Max. CO ₂ custom range	signed int.	Maximum value of CO ₂ custom range, always settable, active only if holding register 7 is set to 1 and register 13 is set to 5	Min - 2.000 (default: 2.000)	2.000 = 2.000 ppm
23	10 minute calibration	signed int.	Setting this register to 1 will perform 10 minute calibration and it will be automatically cleared after the calibration, the sensor measures CO ₂ level for 10 min. and sets the lowest value at 400 ppm (do not turn off the device for 10 min during this procedure!)	0 (default) 1	1 = 10 minute calibration is active

		Data type	Description	Data	Values
24	1 month calibration	signed int	Setting this register to 1 will perform 1 month calibration and is not automatically cleared after the calibration, the sensor measures CO ₂ level for 1 month and sets the lowest value at 400 ppm (during this procedure the device needs to be powered continuously, do not turn off!)	0 (default) 1	1 = 1 month calibration is active
25			Reserved, returns 0		
26			Reserved, returns 0		
27			Reserved, returns 0		
28			Reserved, returns 0		
29			Reserved, returns 0		
30			Reserved, returns 0		
31	Temperature output override value	signed int	Override value for temperature analog output, always settable, active only if holding register 7 and 8 is set to 1	0 - 1000 (default: 0)	0 = 0 VDC 1000 = 10,00 VDC
32	Relative humidity output override value	signed int	Override value for relative humidity analog output, always settable, active only if holding register 7 and 8 is set to 1	0 - 1000 (default: 0)	0 = 0 VDC 1000 = 10,00 VDC
33	CO ₂ output override value	signed int	Override value for CO ₂ analog output, always settable, active only if holding register 7 and 8 is set to 1	0 - 1000 (default: 0)	0 = 0 VDC 1000 = 10,00 VDC
34			Reserved, returns 0		
35			Reserved, returns 0		
36			Reserved, returns 0		
37			Reserved, returns 0		
38			Reserved, returns 0		
39			Reserved, returns 0		
40			Reserved, returns 0		

The manufacturer bears no responsibility for any misprints or mistakes in this data, and modifications or improvements to the product can be made at any time after date of publication.

- All installation shall comply with local requirements and the local electrical code.
- Switch off power supply before connecting power cables.

Maintenance

In normal conditions the device is maintenance-free. If soiled clean with dry or dampish cloth. In case of heavy pollution clean with a non-aggressive product. In these circumstances the device should be disconnected from the mains. Pay attention that no fluids enter the device. Only reconnect to the mains when it is completely dry.

Safety and precautions

The warranty will be void in the event of damage caused by failure to observe these safety instructions. We do not assume liability for any resulting damage. We do not assume any liability for material and personal damage caused by improper use or non-compliance with the safety instructions. In such cases the warranty will be null and void.

- For safety and licensing (CE) reasons, unauthorised conversion and/or modifications to the product are not permitted.
- Indoor use only, the product must not be exposed to extreme temperatures, direct sunlight or intense vibration.
- If you have any questions which are not answered in this instruction manual, please contact our technical support or consult a professional.
- All works may only be carried out by skilled personnel.